

Streifenfundamente + Querriegel + spez. Fundamente

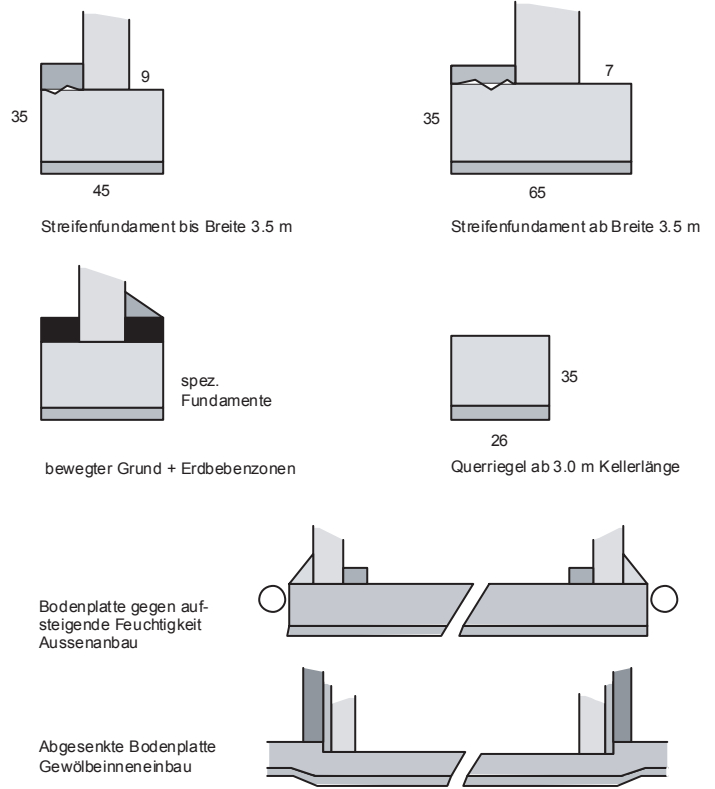

Masse Türausparung seitlich ab 44 cm resp. 55 cm

Oeffnungen + Deckenaussparungen ab Werk

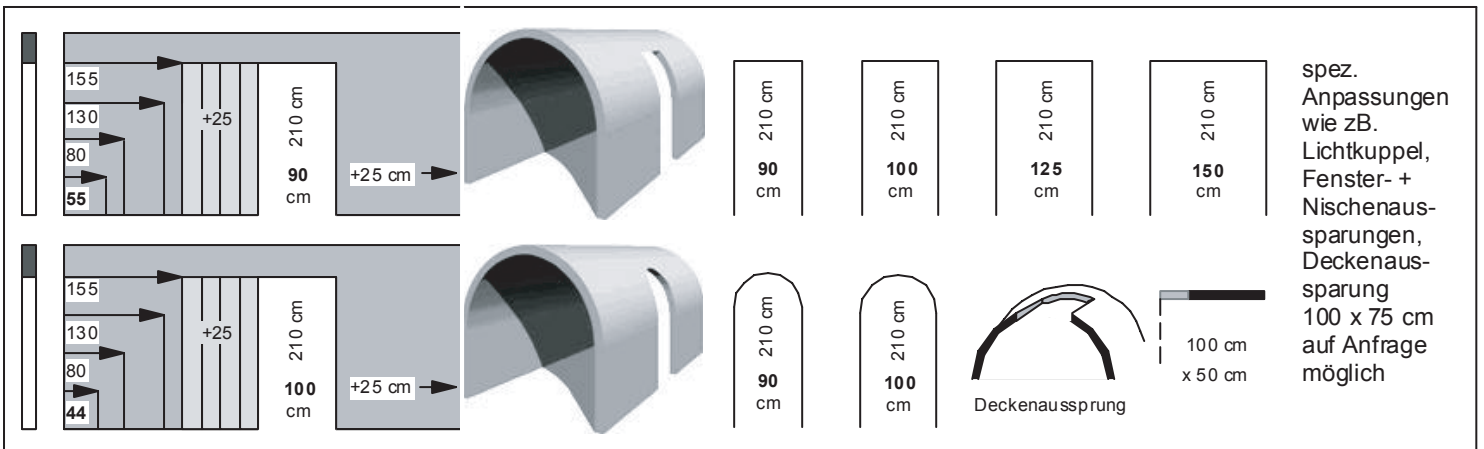

Gewichte

Lüftung

Abdichtung

Dämmung

Belastung der Gewölbe

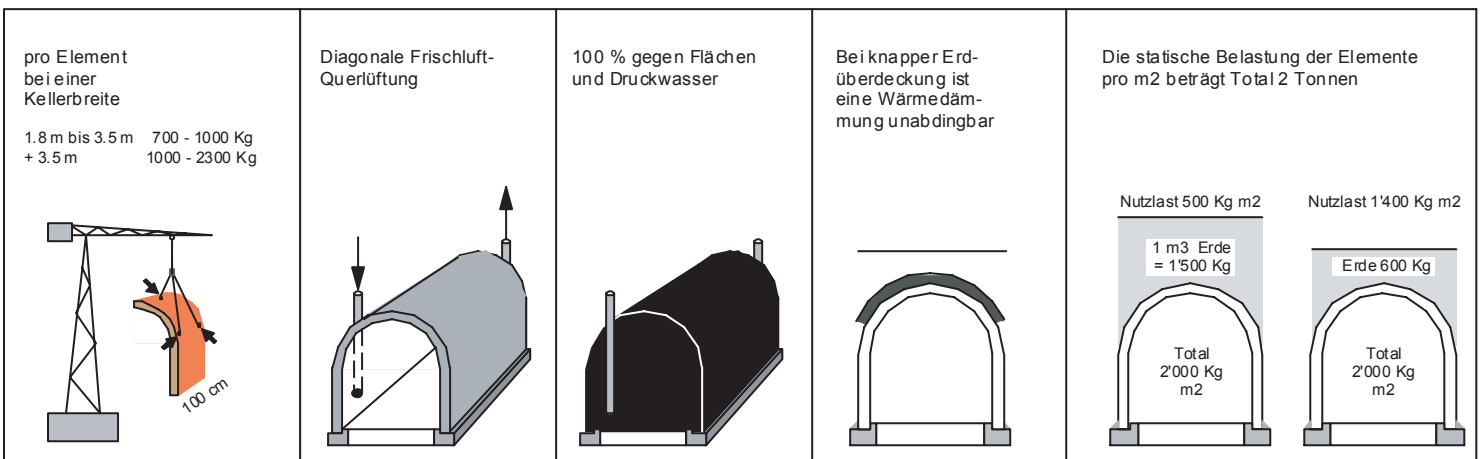

Handels - Agentur
 Rudolf-Kattinig Straße 44 A-9020 Klagenfurt
 www.rundumwein.at

Tel.: 0463-261301 Fax: 0463-218909 Mobil.: 0664-1817779
 e-mail: info@rundumwein.at

Walter Grantner